

JVC

SERVICE MANUAL

DVD/CD PLAYER

KV-DV7

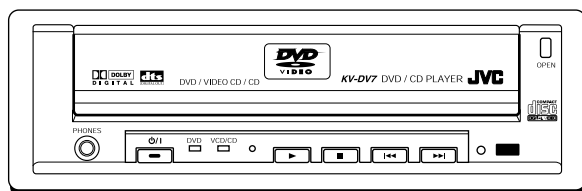

Area Suffix

E	-----	Continental Europe
J	-----	Northern America
UF	-----	China
UT	-----	Taiwan
US	-----	Singapore
A	-----	Australia



Contents

Safety precaution	1-2
Important for laser products	1-3
Disassembly method	1-4
Adjustment method	1-11
Description of major ICs	1-12~17

Safety precaution

 **CAUTION** Burrs formed during molding may be left over on some parts of the chassis. Therefore, pay attention to such burrs in the case of performing repair of this system.

 **CAUTION** Please use enough caution not to see the beam directly or touch it in case of an adjustment or operation check.

Important for laser products

1.CLASS 1 LASER PRODUCT

2.DANGER : Invisible laser radiation when open and interlock failed or defeated. Avoid direct exposure to beam.

3.CAUTION : There are no serviceable parts inside the Laser Unit. Do not disassemble the Laser Unit. Replace the complete Laser Unit if it malfunctions.

4.CAUTION : The compact disc player uses invisible laserradiation and is equipped with safety switches which prevent emission of radiation when the drawer is open and the safety interlocks have failed or are defeated. It is dangerous to defeat the safety switches.

5.CAUTION : If safety switches malfunction, the laser is able to function.

6.CAUTION : Use of controls, adjustments or performance of procedures other than those specified herein may result in hazardous radiation exposure.

⚠ CAUTION Please use enough caution not to see the beam directly or touch it in case of an adjustment or operation check.

VARNING : Osynlig laserstrålning är denna del är öppnad och spärren är urkopplad. Betrakta ej strålen.

VARO : Avattaessa ja suojalukitus ohitettaessa olet alttiina näkymättömälle lasersäteilylle. Älä katso säteeseen.

ADVARSEL : Usynlig laserstråling ved åbning , når sikkerhedsafbrydere er ude af funktion. Undgå udsættelse for stråling.

ADVARSEL : Usynlig laserstråling ved åbning, når sikkerhedsbryteren er avslott. unngå utsettelse for stråling.

REPRODUCTION AND POSITION OF LABELS

WARNING LABEL

DANGER : Invisible laser radiation when open and interlock or defeated.
AVOID DIRECT EXPOSURE TO BEAM (e)

VARO : Avattaessa ja suojalukitus ohitettaessa olet alttiina näkymättömälle lasersäteilylle. Älä katso säteeseen. (d)

VARNING : Osynlig laserstrålning är denna del är öppnad och spärren är urkopplad. Betrakta ej strålen. (s)

ADVARSEL : Usynlig laserstråling ved åbning , når sikkerhedsafbrydere er ude af funktion. Undgå udsættelse for stråling. (f)

**CLASS 1
LASER PRODUCT**

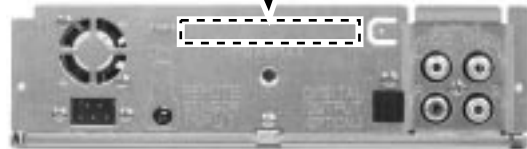
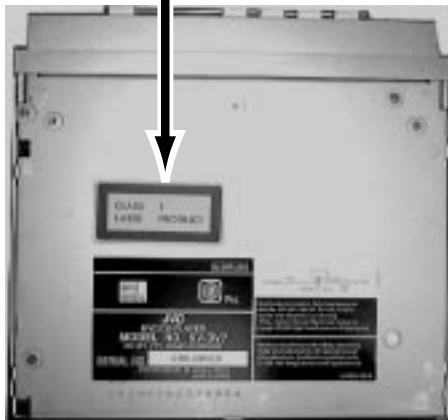

Disassembly method

< Main Body >

■ Removing the top cover (See Fig.1 to 3)

1. Remove the seven screws **A** on both sides and back of the body.
2. Detach the rear part of the top cover upward and release the joint **a** on the top side.

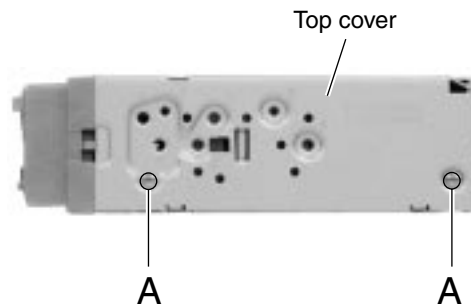

Fig.1

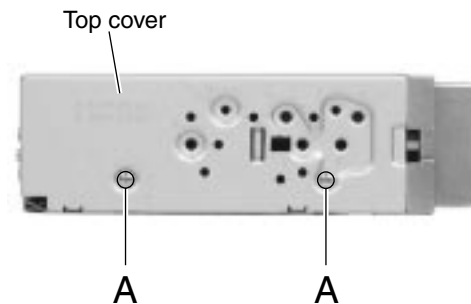

Fig.2

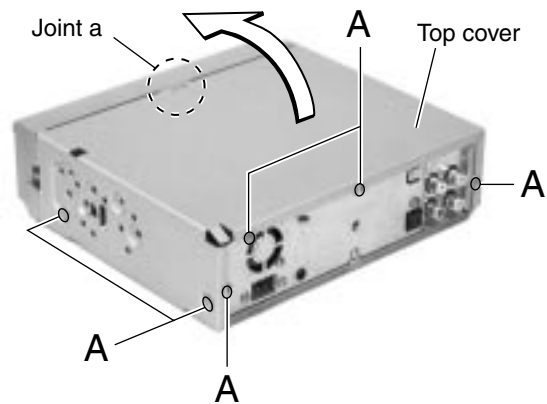

Fig.3

■ Removing the front panel assembly (See Fig.4 to 6)

· Prior to performing the following procedure, remove the top cover.

1. Remove the screw **B** attaching the ground on the top of the body.
2. Remove the four screws **C** and two screws **C'** attaching the front panel assembly on both sides of the body.
3. Release the two joints **b** of the front panel assembly and the bottom chassis on both sides of the body and remove the front panel assembly toward the front.

The connector CN801 on the control switch board in the front panel assembly will be disconnected from the main board.

CAUTION: When reassembling, attach the four screws **C** and then the two screws **C'**.

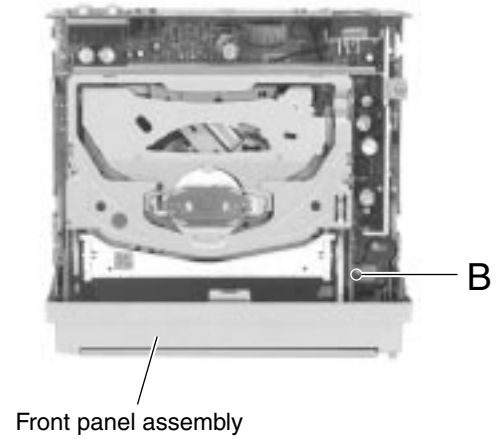

Fig.4

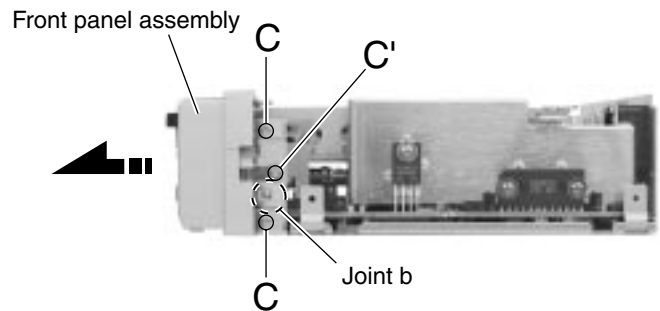

Fig.5

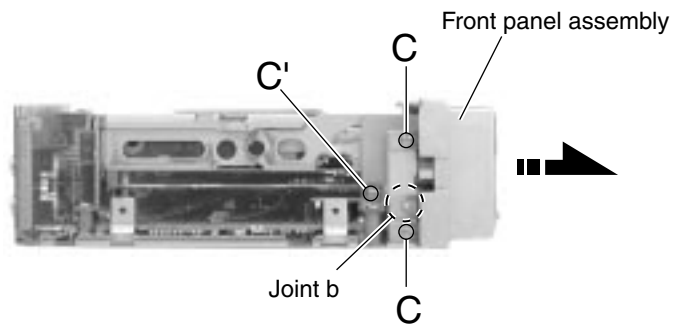

Fig.6

■ Removing the DVD mechanism assembly (See Fig.7 to 11)

- Prior to performing the following procedure, remove the top cover and the front panel assembly.

1. Remove the four screws **D** attaching the DVD mechanism assembly on the top of the body.
2. Remove the DVD mechanism assembly while holding the part **c** on each side of the assembly.

CAUTION: To protect accuracy of the mechanism bracket on the front of DVD mechanism assembly, make sure to hold the part **c** on each side of the DVD mechanism assembly when removing or reassembling.

3. Disconnect the card wire from connector CN721 and CN701 on the main board and remove the DVD mechanism assembly from the body.
4. Remove the two screws **E** attaching the DVD mechanism bracket (1) on the front side of the DVD mechanism assembly.
5. Remove the two screws **F** attaching the DVD mechanism bracket (2) on the rear side of the DVD mechanism assembly.

CAUTION: When reassembling the DVD mechanism assembly, attach the cooling rubber and the heat sink to the DVD mechanism board as shown in Fig.11 to make sure radiation of IC15 on the DVD mechanism board (Fig.11).

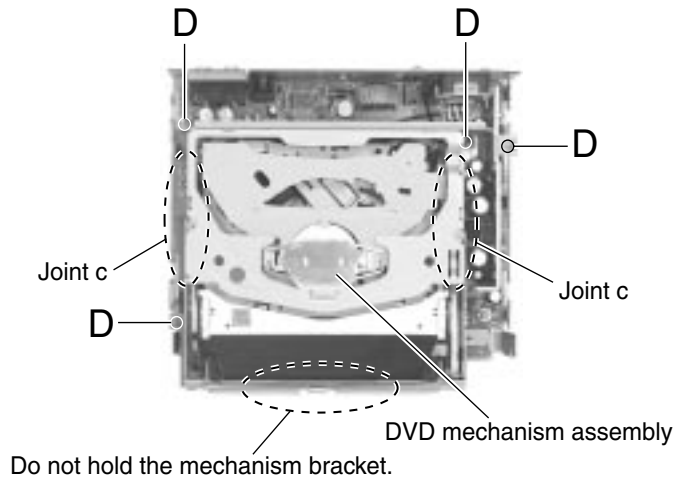

Fig.7

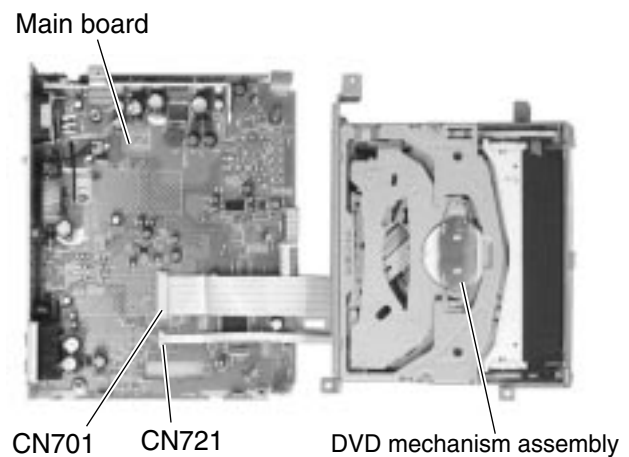

Fig.8

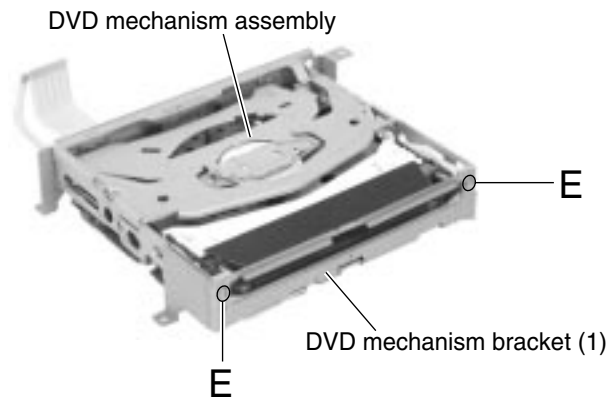

Fig.9

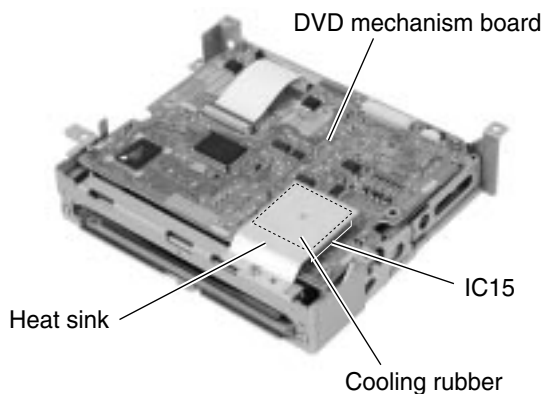

Fig.11

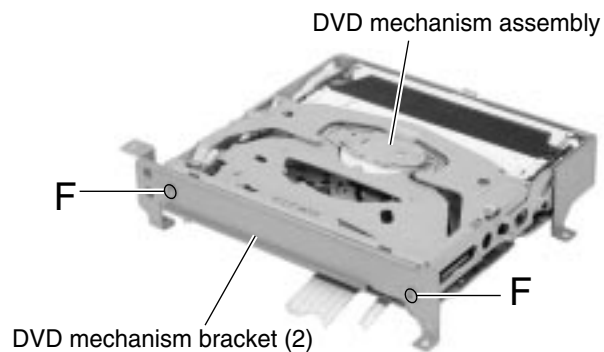

Fig.10

■ Removing the main board (See Fig.12 to 15)

· Prior to performing the following procedure, remove the top cover, the front panel assembly and the DVD mechanism assembly.

1. Disconnect the wire from connector CN781 on the main board.
2. Remove the three screws **G** on the top of the body.
3. Remove the screw **H** on the back of the body.
4. Disengage the joint **d** in the lower right part of the rear panel and remove the rear panel with the main board (The fan assembly will be detached with the rear panel).

CAUTION: When reattaching, engage the joint **c** to place the rear panel on the back of the bottom chassis.

5. Remove the two screws **I** and **J** attaching the main board to the rear panel.

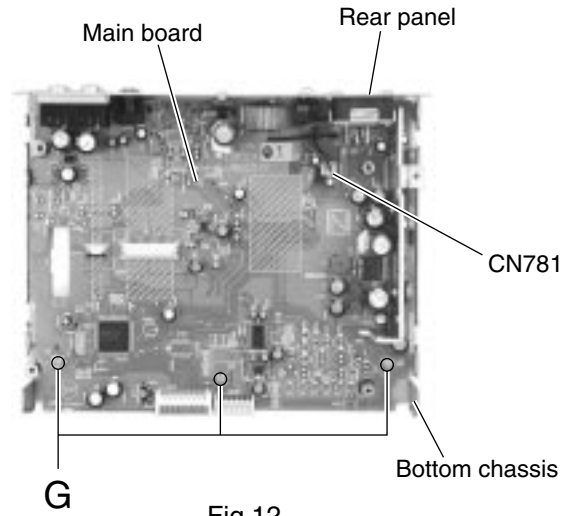

Fig.12

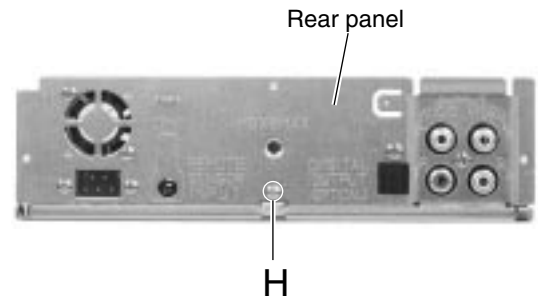

Fig.13

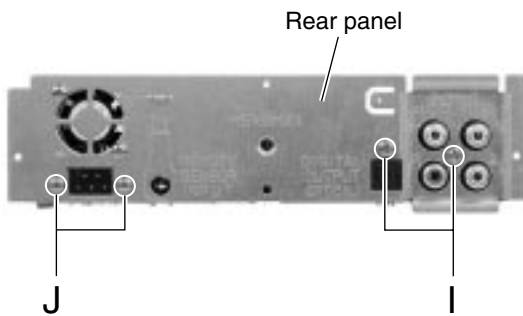

Fig.15

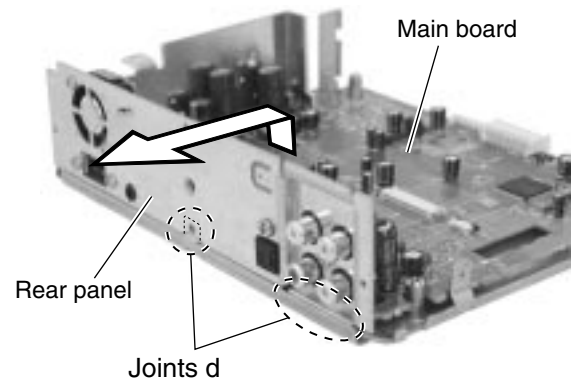

Fig.14

■ Removing the fan assembly (See Fig.16 and 17)

- Prior to performing the following procedure, remove the top cover, the front panel assembly and the DVD mechanism assembly.

REFERENCE: It is not unnecessary to remove the main board and the rear panel.

1. Disconnect the wire from connector CN781 on the main board.
2. Remove the two screws **K** on the back of the body.

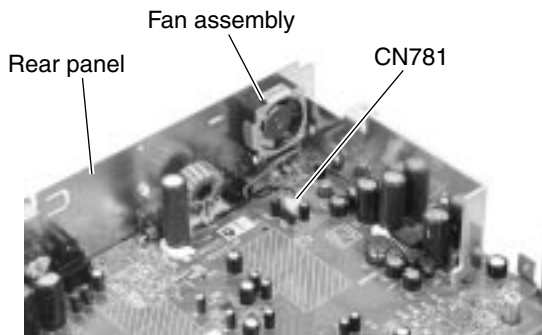

Fig.16

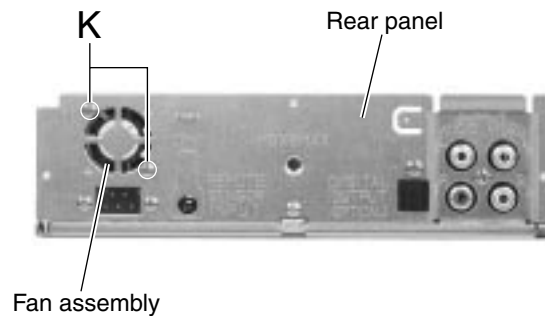

Fig.17

■ Removing the control switch board (See Fig.18)

- Prior to performing the following procedure, remove the top cover and the front panel assembly.

1. Remove the three screws **L** attaching the control switch board on the back of the front panel assembly.
2. Disengage the three joints **e** of the front panel and the control switch board.

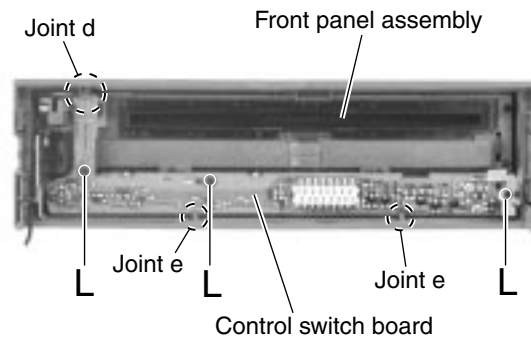

Fig.18

■ Replacing the DVD door flame
(See Fig.19 to 24)

· Prior to performing the following procedure, remove the front panel assembly and the control switch board.

1. Remove each button on the back of the front panel.
2. Press the OPEN button on the front side of the front panel to open the DVD door.
3. Remove the six screws **M** attaching the DVD door flame on the back of the front panel.
4. Disengage the three joints **f** on the top of the DVD door flame using a screwdriver (-) to pull out the three bosses of the front panel. Peel off the two adhesive tapes at the same time.
5. Detach the bottom of the DVD door flame. Press the lock lever on the front side of the front panel and remove the DVD door flame from the gear.

CAUTION: When reassembling, reattach the DVD door flame to the front panel with the two adhesive tapes while engaging the three joints **f**.

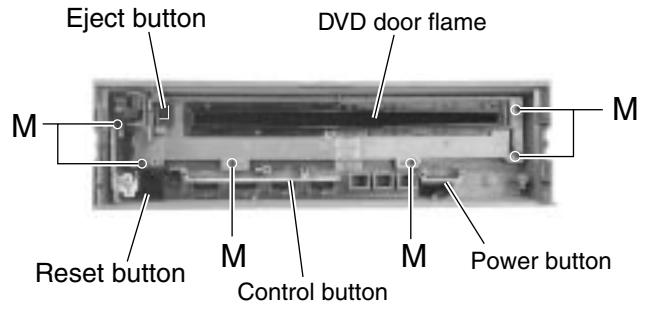

Fig.19

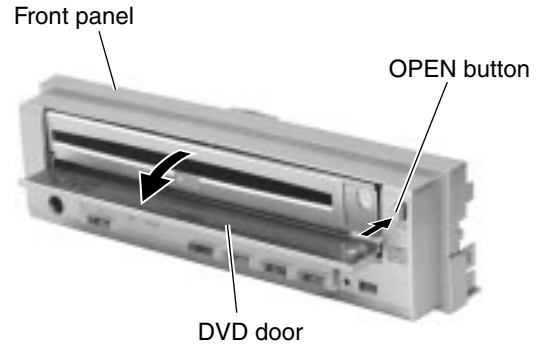

Fig.20

Detach the lock lever from the front side, then from the gear.
 DVD door flame (remove from bottom)

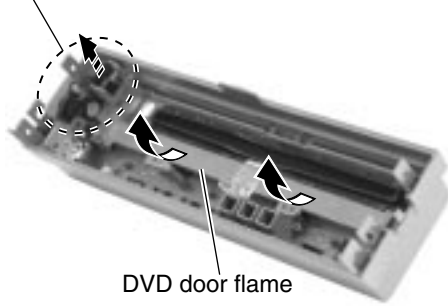

Fig.22

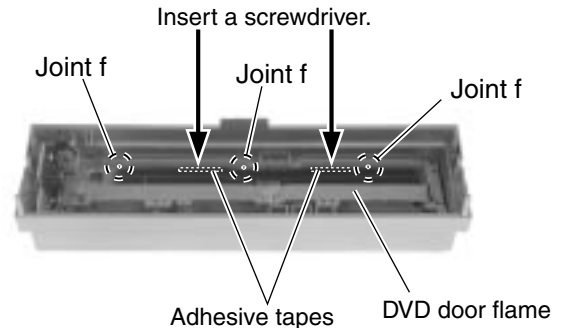

Fig.21

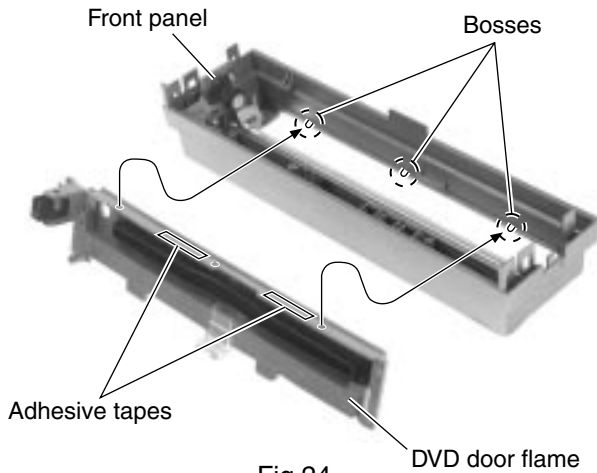

Fig.24

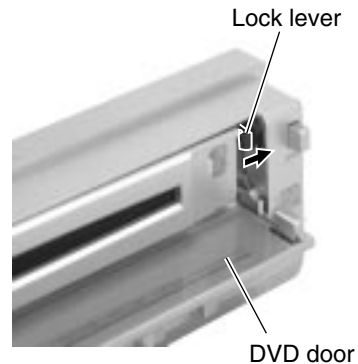

Fig.23

■ Removing the DVD door

(See Fig.25 to 29)

• Prior to performing the following procedure, remove the front panel assembly, the control switch board and the DVD door flame.

1. Remove the screw **N** attaching the gear assembly on the back of the front panel.
2. Pull out the DVD door shaft from the joint **g** of the DVD door and the front panel.
3. Remove the DVD door with the gear assembly.
4. Remove the spring through the notch **h** of the gear assembly bracket and remove the DVD door from the gear assembly.

CAUTION: Do not lose the spring.

CAUTION: Reattaching the DVD door, reattach the spring through the notch **h** and hole **i** of the gear assembly bracket, then reassemble the DVD door and the gear assembly. Reattach them to the front panel.

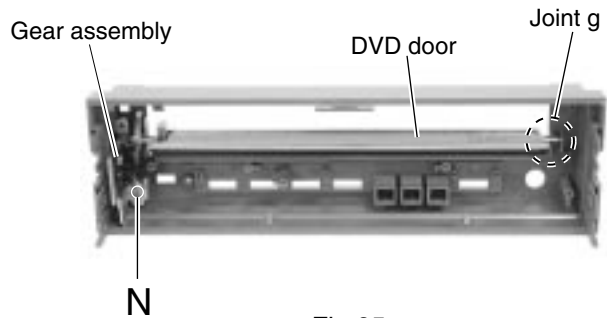

Fig.25

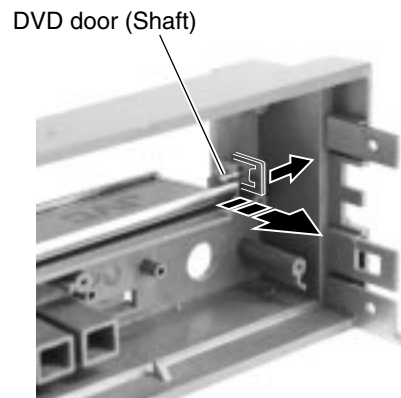

Fig.26

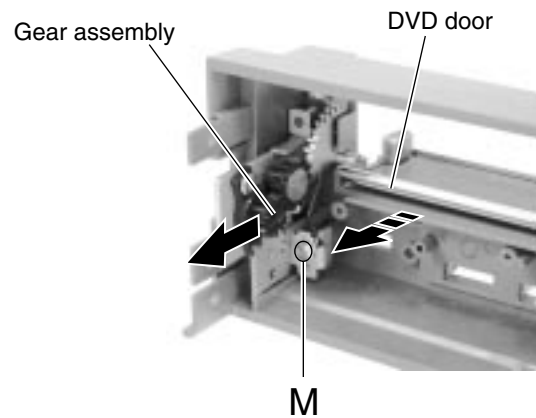

Fig.27

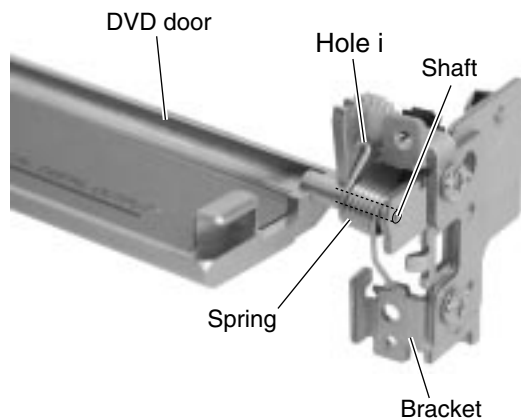

Fig.29

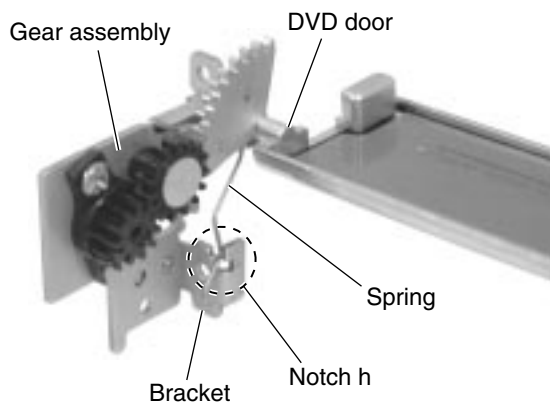

Fig.28

Adjustment method

This model dose not have adjustment.

If you change printed circuit board or mechanism assembly, please check as folow as next.

■ Test instruments required for checking

- (1) Digital oscilloscope (100MHz)
- (2) AM standard signal generator
- (3) FM standard signal generator
- (4) Stereo modulator
- (5) Electric voltmeter
- (6) Digital tester
- (7) Monitor
- (8) Test disc : VT-501 for DVD section
: CTS-1000 for CD section

■ Checking items

- (1) DVD section: Playback the test disc VT-501.
It should not have some noise on the audio signal or video signal.
- (2) CD section : Playbcak the test disc CTS-1000.
It should not heve some noise on the audio signal.

Description of major ICs

■ UPD780058GC-250 (IC701) : Micon

1. Pin layout

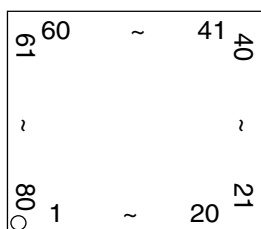

2. Pin function (1/2)

Pin No.	Symbol	I/O	Function
1	TEMP	I	Temperature sensor
2	-	I	Non connect
3	-	I	Non connect
4	AVSS	-	Audio ground
5	LCDCONT		LCD control
6	D_OUT_MUTE	O	Digital out mute
7	AVREF1	-	Analog reference voltage
8	LCDDI/RXDO	I	Communication for JIG LCD or PC
9	LCDDO/TXDO	O	Communication for JIG LCD or PC
10	LCDCL/ASCK	O	Communication for JIG LCD or PC
11	JBUS_SI	I	J-BUS serial input
12	JBUS_SO	O	J-BUS serial output
13	JBUS_SCK	I	J-BUS serial clock input
14	JBUS_CTRL+B	-	Power supply for J-BUS control
15	ANT_FM	O	Communication for DVD mechanism
16	D_HOST	I	Communication for DVD mechanism
17	D_FM	O	Communication for DVD mechanism
18	SCK	I	Communication for DVD mechanism
19	RDY_FM	O	Communication for DVD mechanism
20	/HOST_RST	O	Communication for DVD mechanism
21	NTSC/PAL	O	NTSC/PAL control (H:PAL L:NTSC)
22	E.VOL_SCK	O	E. volume serial clock output
23	E.VOL_DO	O	E. volume data output
24	E.VOL_STB	O	E. volume strobe output
25	V_MUTE	O	Video mute output
26	A_MUTE	O	Audio mute output
27	D_MUTE	I	Audio mute input
28	LED_DISCIN	O	LED output for slot
29	LED_DSP	O	LED output for Real sonic or Remocon
30	LED_CD/DVD	O	LED output for CD/DVD
31	LED_DVD	O	LED output for DVD
32	EEPROM_DO	-	Non connect
33	VSS1	-	Ground1
34	EEPROM_DI	-	Non connect
35	EEPROM_CLK	-	Non connect
36	EEPROM_CONT	-	Non connect
37	FANCONT	O	Fan control
38	-	-	Non connect
39	-	-	Non connect
40	LCDCE	-	LCD chip select

2. Pin function (2/2)

Pin No.	Symbol	I/O	Function
41	LCDRST	-	Non connect
42	JBUS_I/O	I/O	J-BUS I/O
43	S1_CONT		S1 control
44	SIDE_BRAKE	I	Side brake detection
45	HEADPHONE	I	Headphone detection
46	REMOCON_SEL	I	Remocon code select
47	SB_SEL_V	I	Side brake select
48	SB_SEL_OP	I	Side brake select
49	LCD/PC_SEL	I	Communication select
50	ADDRESS_SEL	I	Address select on J-BUS
51	NTSC/PAL_SEL	I	NTSC/PAL select
52	VSYNC		
53	POWER_CONT	O	Power supply control
54	+7V_CONT	O	Mechanism power supply +7V control
55	+5V_CONT	O	Mechanism power supply +5V control
56	LED_CONT	O	Power supply control od LED & Remocon
57	PLAY_REMOTE	O	Play remote output
58	LINE_IN	I	LINE IN control
59	CD_DET	-	Non connect
60	RESET	I	Reset
61	J-INT	O	J-BUS initialize
62	P.SAVE2(BATT)	I	Battery detection
63	P.SAVE1(ACC)	I	ACC detection
64	FM_INT	I	DVD mechanism communication
65	REMOCON	I	Remocon input
66	KEY_INT	I	KEY_INT
67	VSS0	I	Setting to input for common use
68	VDD1		Power supply1
69	X2		Connect to X'tal
70	X1		Connect to X'tal
71	IC		
72	XT2	-	Non connect
73	XT1		Power supply
74	VDD0	O	Power supply 0
75	AVREF0	O	Referencew voltage
76	ANI0	I	Key input 0
77	ANI1	I	Key input 1
78	ANI2	I	Key input 2
79	ANI3	I	Key input 3
80	ANI4	I	Key input 4

BA4901A-V3 (IC911) : Regulator

1. Pin layout

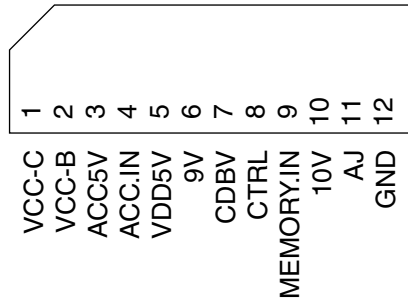

2. Pin Function

Pin No.	Symbol	Descriptions
1	VCC-C	To be connected with the collector of PNP.
2	VCC-B	To be connected with the base of PNP.
3	ACC5V	A voltage supply for ACC block.
4	ACC.IN	Control of the COMP output by inputting voltage.
5	VDD5V	Output voltage level is 5.7V, and max output current is 100mA. This voltage supply is for microcomputer. Whenever backup voltage supply is connected, the output keeps on running.
6	9V	This output voltage is 9.0V, and max output current is 500mA. This voltage supply for AUDIO.
7	CDBV	This output voltage is 8.0V, and max output current is 1A. This voltage supply for CD.
8	CTRL	Output selector of CD, AUDIO, ILM and Vcc-B.
9	MEMORY.IN	To be connected with the BACKUP of car
10	10V	This output voltage is 10V, and max output current is 500mA. Output voltage is adjustable.
11	AJ	Putting a resistance between ILM and AJ or between AJ and GND males ILM output voltage adjustable.
12	GND	Connect to GND

LM2596S-ADJ-W (IC951) : Regulator

1. Pin layout

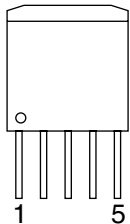

2. Block diagram

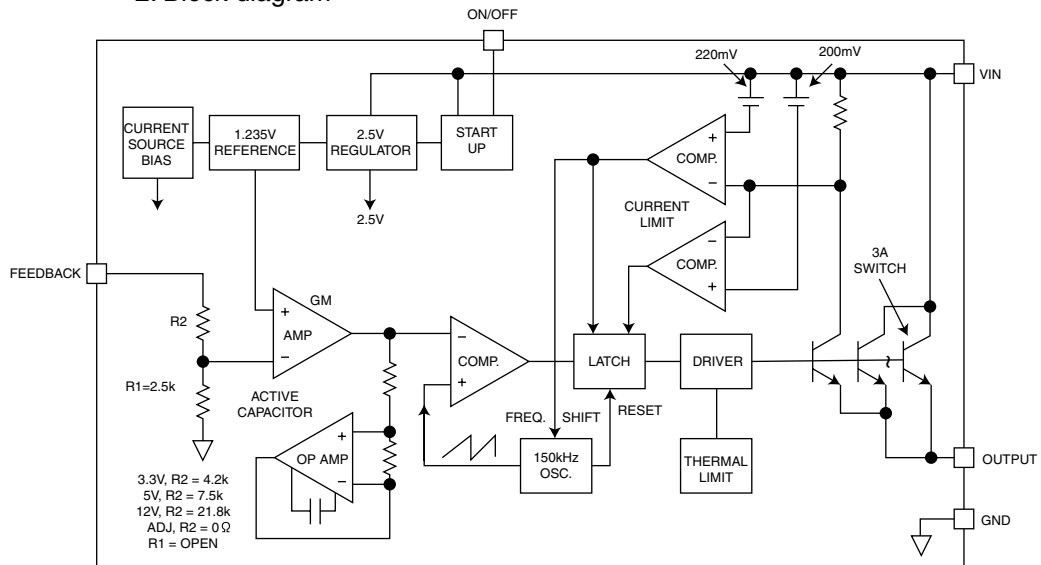

■ IC-PST9333U-X (IC741) : Regulator

1. Pin layout

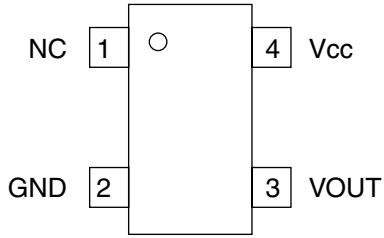

2. Block diagram

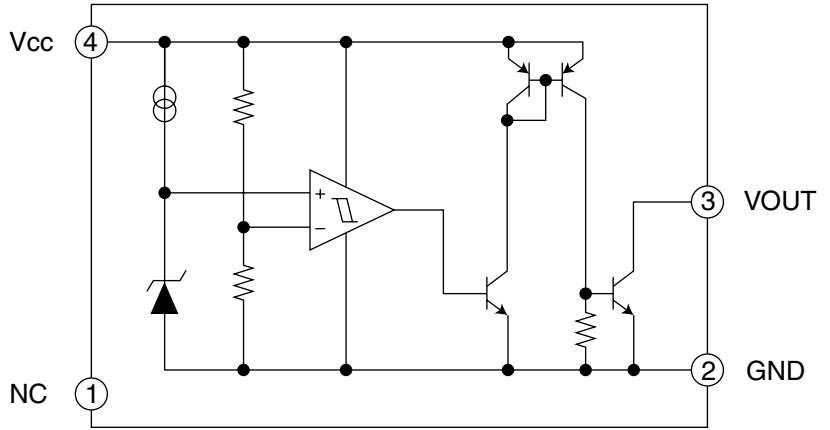

3. Pin function

Pin No.	Symbol	Function
1	NC	Non connect
2	GND	GND terminal
3	VOUT	Reset signal output terminal
4	Vcc	Vcc terminal/Voltage detect terminal

■ NJM2267X-X (IC301) : Video amp.

1. Pin layout

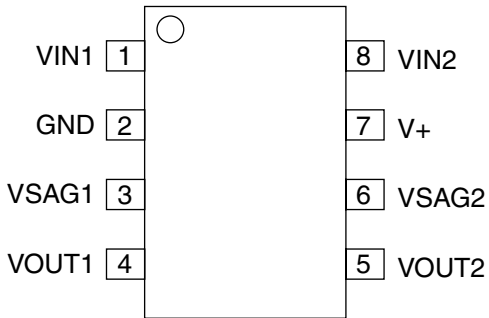

2. Block diagram

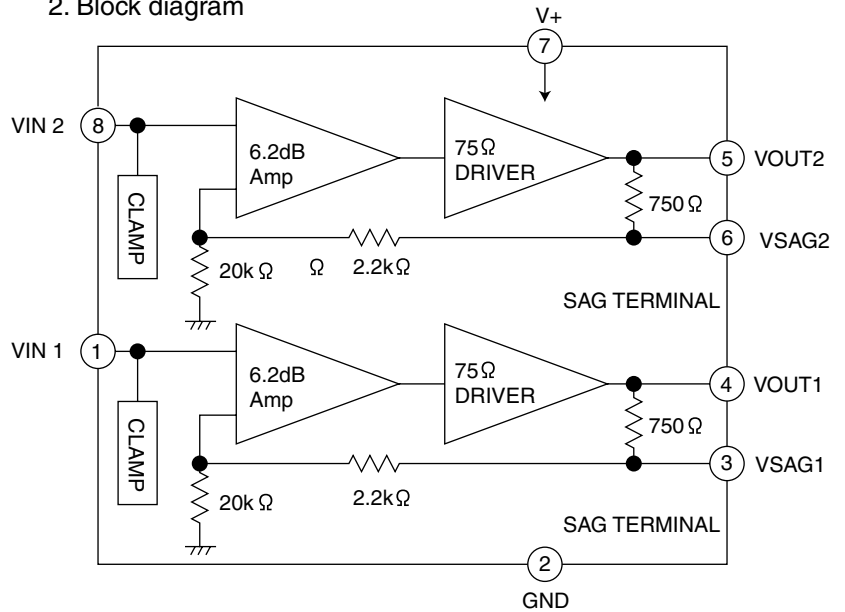

■ NJM4580V-X (IC101,IC151) : Ope amp.

1. Pin layout & Block diagram

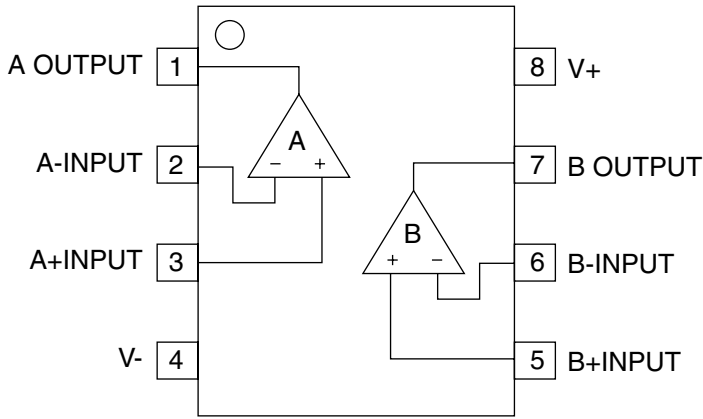

■ PQ05RD21 (IC961) : Regulator

1. Block diagram

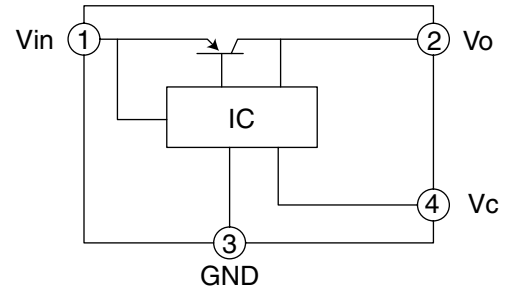

■ RPM6938-V4 (IC801) : Remocon reseiver

1. Block diagram

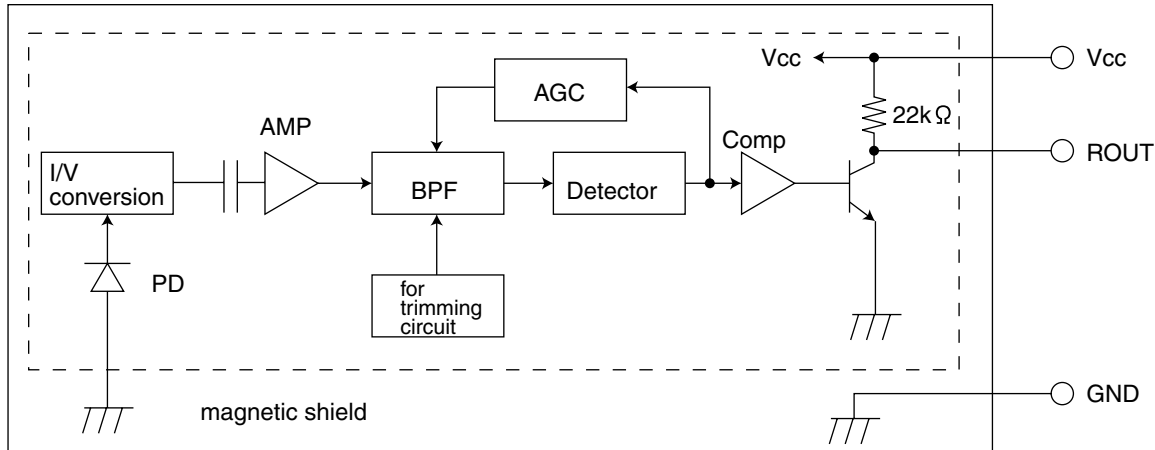

■ TA78L05F-X (IC971) : Regulator

1. Pin layout

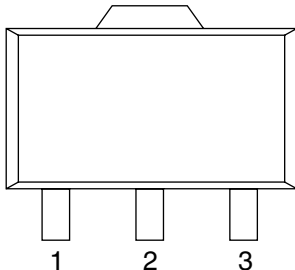

■ TC7SET08F-X (IC511) : Regulator

1. Pin layout

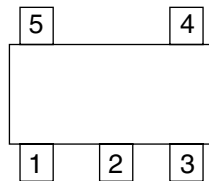

2. Truth table

A	B	Y
L	L	L
L	H	L
H	L	L
H	H	H

■ TC9260F-X (IC131) : E. volume

1. Pin layout

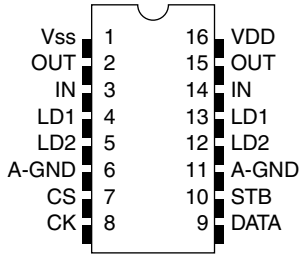

2. Pin function

Pin No.	Symbol	Function
1	Vss	Digital ground terminal
2	L-OUT	Volume output terminal
3	L-IN	Volume input terminal
4	L-LD1	Tap out terminal for loudness(1)
5	L-LD2	Tap out terminal for loudness(2)
6	L-GND	Analog ground terminal
7	CS	Chip select terminal
8	CK	Clock input terminal
9	DATA	Data input terminal
10	STB	Strobe input terminal
11	R-GND	Analog ground terminal
12	R-LD2	Tap output terminal for loudness(2)
13	R-LD1	Tap output terminal for loudness(1)
14	R-IN	Volume input terminal
15	R-OUT	Volume output terminal
16	VDD	Power supply terminal

3. Block diagram

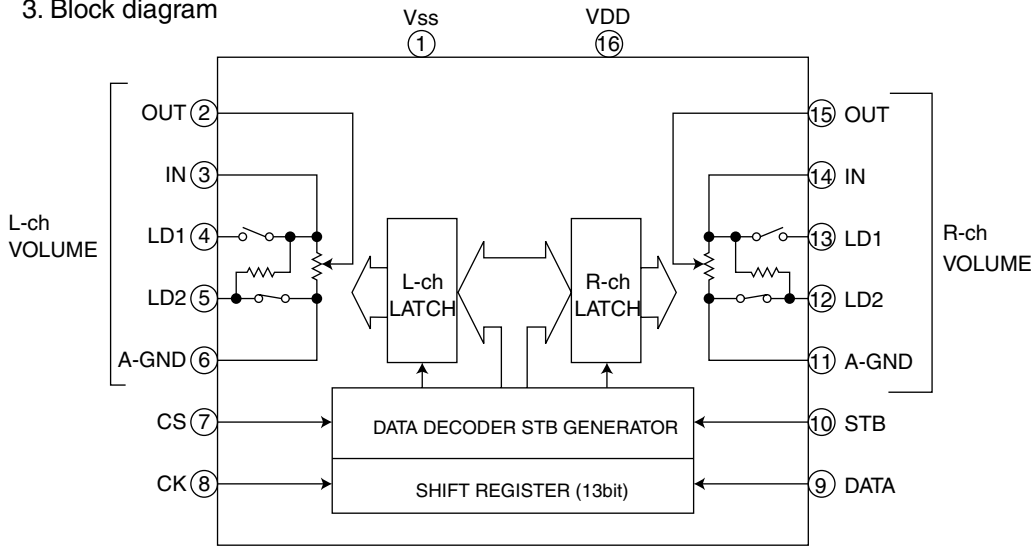



VICTOR COMPANY OF JAPAN, LIMITED

MOBILE ELECTRONICS DIVISION

PERSONAL & MOBILE NETWORK BUSINESS UNIT. 10-1,1Chome,Ohwatari-machi,Maebashi-city,371-8543,Japan